

High Voltage Multiple-Topology LED Driver with Open Detection

General Description

The RT8474A is a current-mode LED driver supporting wide input voltage range from 4.5V to 50V in multiple topologies.

With the internal 500kHz operating frequency, the size of the external PWM inductor and input/output capacitors can be minimized. High efficiency is achieved by a 100mV current sensing control. LED dimming control can be done from either analog or PWM signal. The RT8474A provides an internal soft-start function to avoid inrush current and thermal shutdown to prevent the device from overheat.

The RT8474A is available in the SOP-8 (Exposed pad) package.

Features

- High Voltage : V_{IN} Up to 50V, V_{OUT} Up to 50V
- Support Multiple-Topologies (Buck / Boost / Buck-Boost)
- Built-In 2A Power Switch
- Current-Mode PWM Control
- 500kHz Fixed Switching Frequency
- Analog or PWM Control Signal for LED Dimming
- Internal Soft-Start to Avoid Inrush Current
- OVP Pin for Adjustable OVP Level Protection (for Buck Only)
- Under-Voltage Lockout
- Thermal Shutdown
- RoHS Compliant and Halogen Free

Ordering Information

RT8474A	□□
	Package Type
	SP : SOP-8 (Exposed-Option 2)
	Lead Plating System
	G : Green (Halogen Free and Pb Free)

Note :

Richtek products are :

- ▶ RoHS compliant and compatible with the current requirements of IPC/JEDEC J-STD-020.
- ▶ Suitable for use in SnPb or Pb-free soldering processes.

Applications

- Desk Lights and Room Lighting
- Industrial Display Backlight

Marking Information

RT8474A
GSPYMDNN

RT8474AGSP : Product Number
YMDNN : Date Code

Simplified Application Circuit

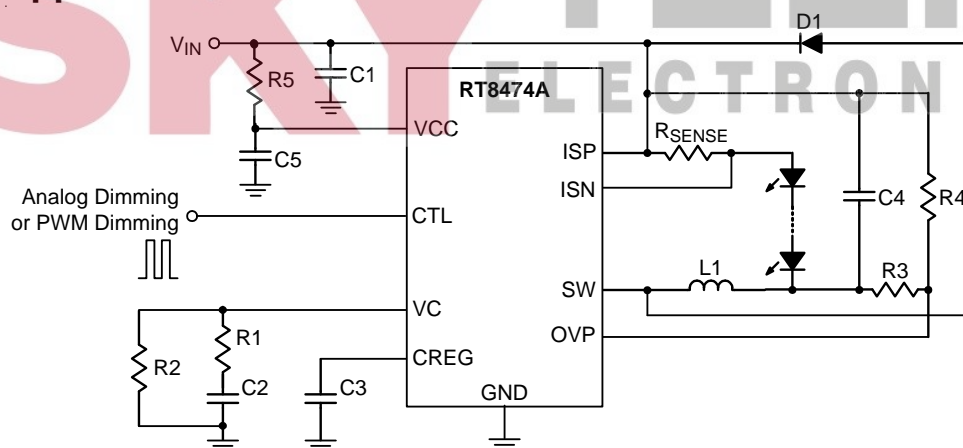

Pin Configurations

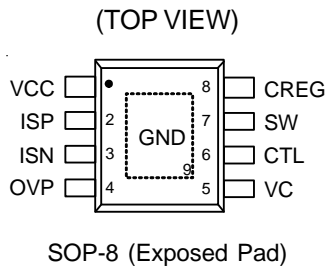

Functional Pin Description

Pin No.	Pin Name	Pin Function
1	VCC	Supply Voltage Input. For good bypass, connect a low ESR capacitor between this pin and GND.
2	ISP	Positive Current Sense Input.
3	ISN	Negative Current Sense Input. Voltage threshold between ISP and ISN is 100mV.
4	OVP	Over-Voltage Protection Sense Input. OVP pin is used for OVP protection function in buck topology only. The OVP pin must be tied to ISP pin in boost and buck-boost topologies.
5	VC	Compensation Node for Current Loop.
6	CTL	Analog Dimming Control Input. Effective programming range is 0.2V to 1.2V.
7	SW	Switch Node of the PWM Converter.
8	CREG	Regulator Output for Internal Circuit. Place a 1μF capacitor to stabilize the 5V output regulator.
9 (Exposed Pad)	GND	Ground. The exposed pad must be soldered to a large PCB and connected to GND for maximum power dissipation.



Function Block Diagram

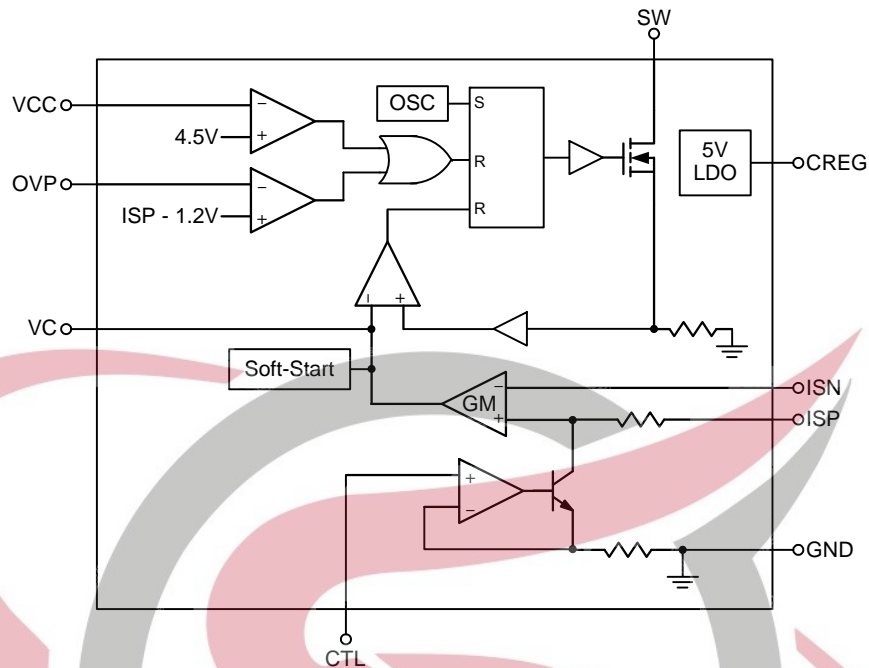

Operation

The RT8474A can be used in multiple topologies. In Buck converter applications, an OVP pin is specially designed to be used for an over voltage protection function.

RT8474A uses a fixed frequency, current-mode control scheme to provide excellent line and load regulation. The control loop has a current sense amplifier which senses the voltage between the ISP and ISN pins and provides an output voltage at the VC pin. A PWM comparator then turns off the internal power switch when the sensed power switch current exceeds the compensated VC pin voltage. The power switch will not be reset by the oscillator clock in each cycle. If the comparator does not turn off the switch in a cycle, the power switch will be on for more than a full switching period until the comparator is tripped. In this manner, the programmed voltage across the sense resistor is regulated by the control loop.

The current through the sense resistor is set by the programmed voltage and the sense resistance. The voltage across the sense resistor can be programmed by the analog or digital signal at the CTL pin. The RT8474A provides protection functions which include over-temperature, and switch current limit to prevent abnormal situations.



Absolute Maximum Ratings (Note 1)

• Supply Input Voltage, VCC	-----	-0.3V to 60V
• SW Pin Voltage at Switching off, ISP, ISN, OVP	-----	-0.3V to 60V
• CREG Voltage	-----	-0.3V to 6V
• CTL Voltage (Note 2)	-----	-0.3V to 20V
• Power Dissipation, P _D @ T _A = 25°C		
SOP-8 (Exposed Pad)	-----	3.44W
• Package Thermal Resistance (Note 3)		
SOP-8 (Exposed Pad), θ _{JA}	-----	29°C/W
SOP-8 (Exposed Pad), θ _{JC}	-----	2°C/W
• Junction Temperature	-----	150°C
• Lead Temperature (Soldering, 10 sec.)	-----	260°C
• Storage Temperature Range	-----	-65°C to 150°C
• ESD Susceptibility (Note 4)		
HBM (Human Body Model)	-----	2kV
MM (Machine Model)	-----	200V

Recommended Operating Conditions (Note 5)

• Supply Input Voltage	-----	4.5V to 50V
• Junction Temperature Range	-----	-40°C to 125°C
• Ambient Temperature Range	-----	-40°C to 85°C

Electrical Characteristics

(V_{CC} = 5V, C_{IN} = 1μF, T_A = 25°C, unless otherwise specified)

Parameter	Symbol	Test Conditions	Min	Typ	Max	Unit
Overall						
Regulator Output Voltage	V _{CREG}	I _{CREG} = 20mA	4.5	5	5.5	V
Supply Current	I _{VCC}	V _C ≤ 0.4V	--	--	3	mA
VIN Under-Voltage Lockout Threshold	V _{UVLO}	V _{IN} Rising	--	4.2	4.5	V
		V _{IN} Falling	3.9	4.1	--	
Current Sense Amplifier						
Input Threshold (V _{ISP} - V _{ISN})		V _{CTL} ≥ 1.25V	97	100	103	mV
Input Current	I _{ISP}	V _{ISP} = 24V	--	200	--	μA
Input Current	I _{ISN}	V _{ISN} = 24V	--	20	--	μA
Output Current	I _{VC}	2.4V > V _C > 0.3V	--	±10	--	μA
VC Threshold for CTL Switch Off			--	0.4	--	V
LED Dimming						
Input Current of CTL Pin	I _{CTL}	0.2V ≤ V _{CTL} ≤ 1.2V	--	1	2	μA
LED Current Off Threshold at CTL	V _{CTL_OFF}		0.15	0.2	0.25	V
LED Current On Threshold at CTL	V _{CTL_ON}		--	1.2	1.5	V

Parameter	Symbol	Test Conditions	Min	Typ	Max	Unit
PWM Converter						
Switch Frequency	f _{SW}		440	500	540	kHz
Maximum Duty Cycle	D _{MAX}		--	--	100	%
Minimum On-Time			--	100	200	ns
SW R _{DS(ON)}			--	0.15	--	Ω
SW Current Limit	I _{LIM_SW}		2	2.5	--	A
Over-Voltage Protection and Soft-Start						
OVP Threshold	V _{OVP}	V _{ISP} – V _{OVP}	1.15	1.2	1.25	V
OVP Recovery		V _{OVP} = 1.2V	--	1	--	V
OVP Input Current	I _{OVP}	V _{OVP} ≤ 1.5V	--	30	--	μA
Soft-Start Time		(Note 6)	--	5.7	--	ms
Over-Temperature Protection						
Thermal Shutdown Threshold	T _{SD}		--	150	--	°C
Thermal Shutdown Hysteresis	ΔT _{SD}		--	20	--	°C

Note 1. Stresses beyond those listed “Absolute Maximum Ratings” may cause permanent damage to the device. These are stress ratings only, and functional operation of the device at these or any other conditions beyond those indicated in the operational sections of the specifications is not implied. Exposure to absolute maximum rating conditions may affect device reliability.

Note 2. If connected with a 20kΩ serial resistor, PWM can go up to 40V.

Note 3. θ_{JA} is measured at T_A = 25°C on a high effective thermal conductivity four-layer test board per JEDEC 51-7. θ_{JC} is measured at the exposed pad of the package.

Note 4. Devices are ESD sensitive. Handling precaution is recommended.

Note 5. The device is not guaranteed to function outside its operating conditions.

Note 6. Guarantee by design, not subject to production testing.



Typical Application Circuit

Buck Configuration

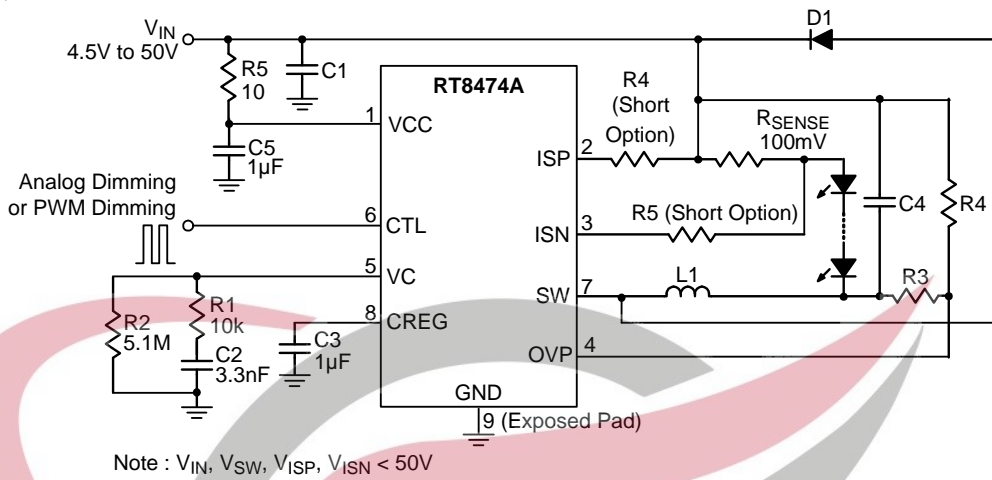

Boost Configuration

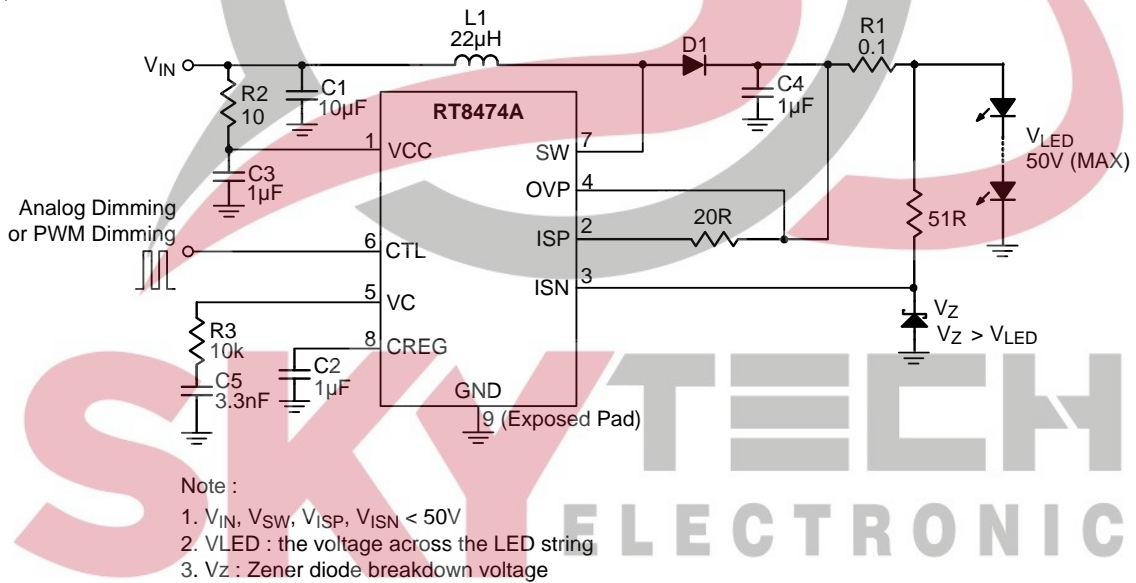

Buck-Boost Configuration

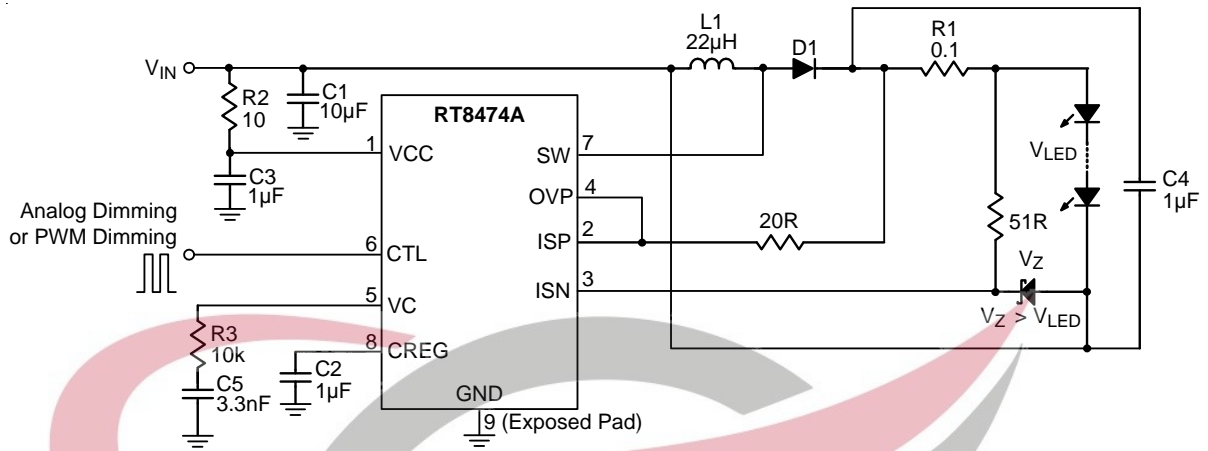

- Note :
1. $V_{SW} < 50V, V_{IN} + V_{LED} < 50V$
 2. V_{LED} : the voltage across the LED string
 3. V_z : Zener diode breakdown voltage



Typical Operating Characteristics

Efficiency vs. Input Voltage

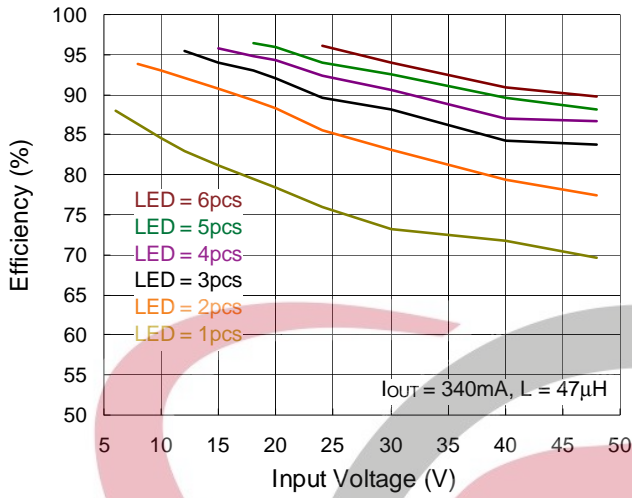

LED Current vs. V_{CTL}

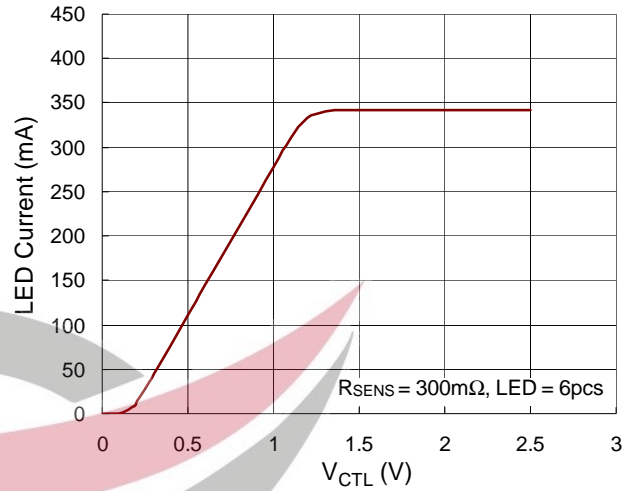

Supply Current vs. VCC

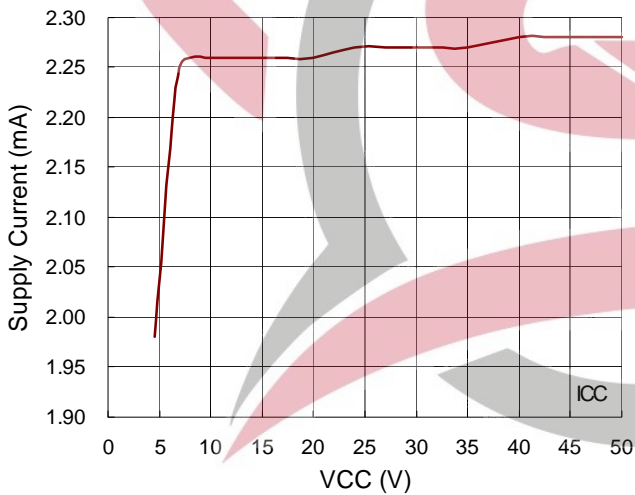

ISP-ISN Threshold vs. Temperature

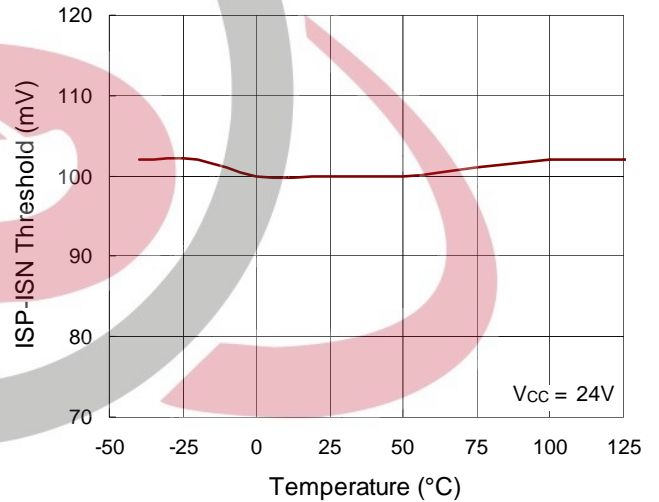

SW $R_{DS(ON)}$ vs. VCC

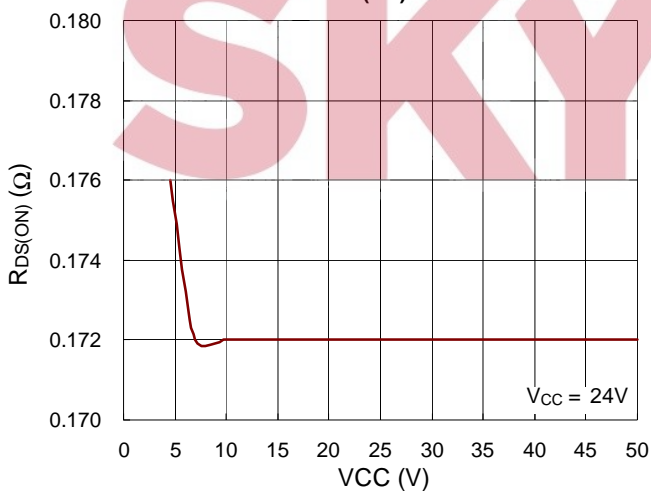

SW $R_{DS(ON)}$ vs. Temperature

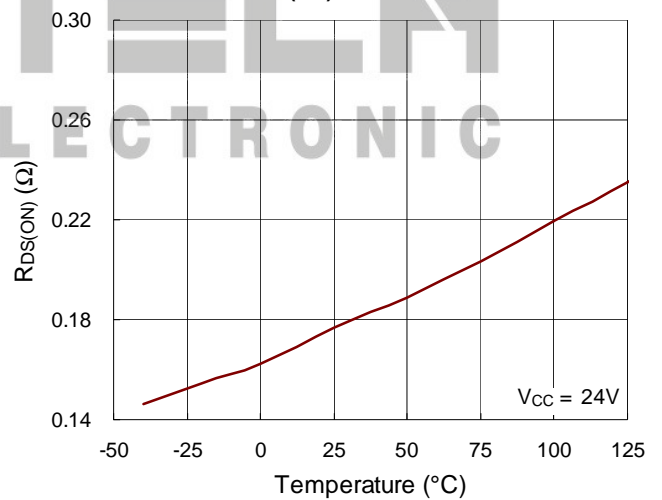

OVP Voltage vs. Temperature

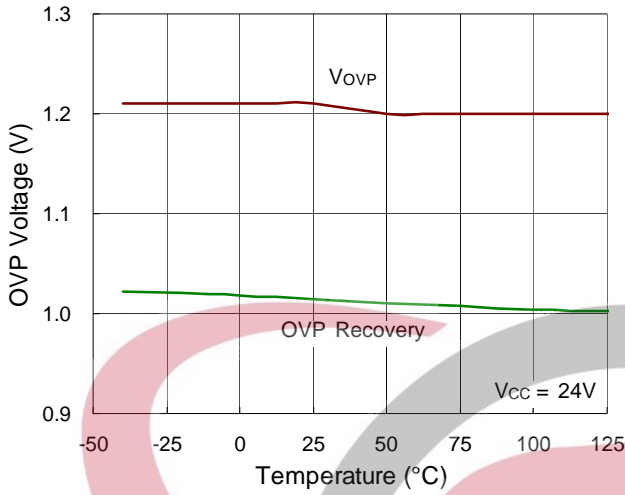

Frequency vs. VCC

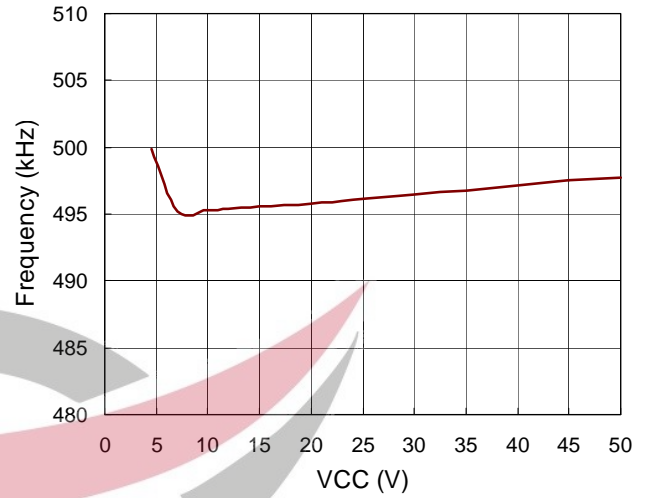

Power On from VCC

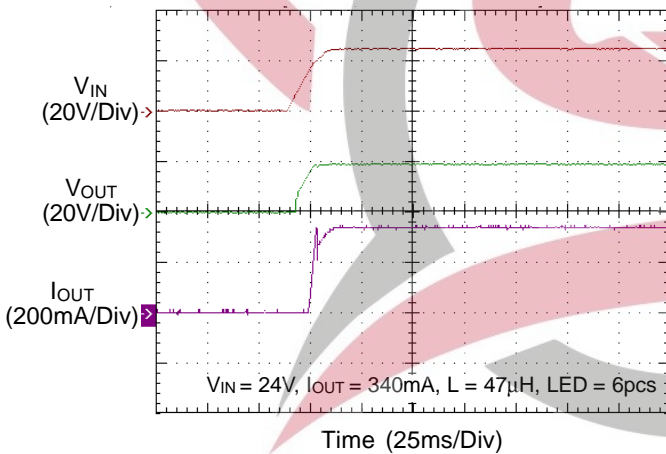

Power Off from VCC

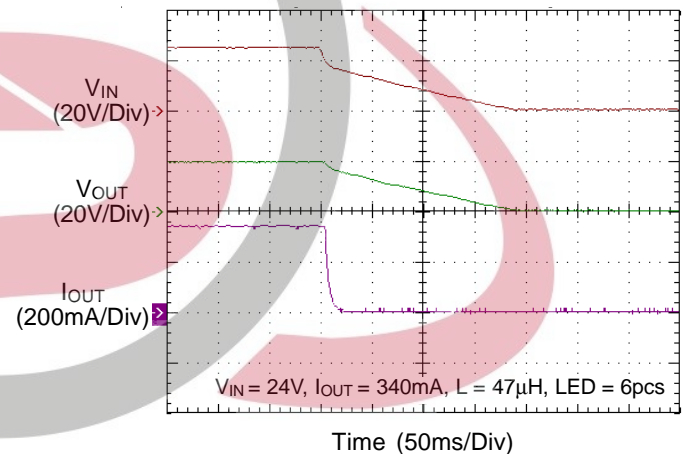

OVP Turn On when LED Take Off and Restore

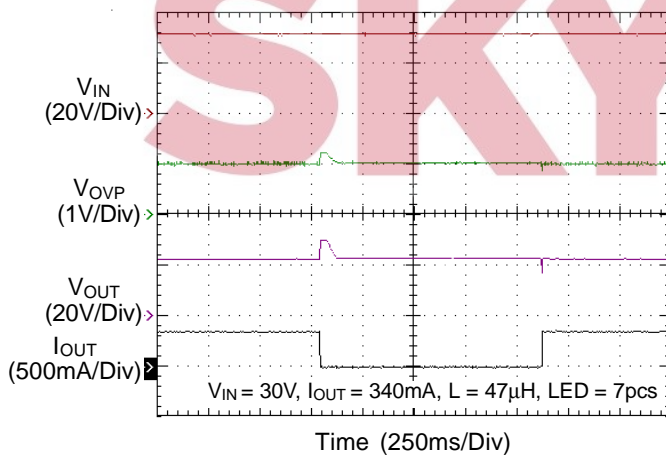

Switching

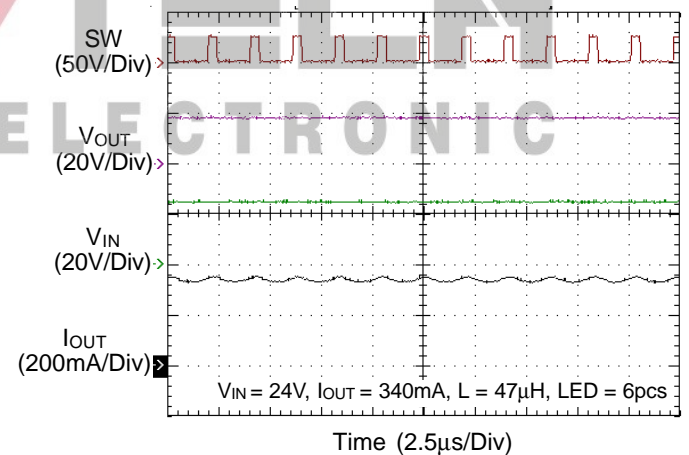

Application Information

The RT8474A can be used in multiple topologies. In Buck converter applications, an OVP pin is specially designed to be used for an over voltage protection function.

RT8474A uses a fixed frequency, current-mode control scheme to provide excellent line and load regulation. The control loop has a current sense amplifier which senses the voltage between the ISP and ISN pins and provides an output voltage at the VC pin. A PWM comparator then turns off the internal power switch when the sensed power switch current exceeds the compensated VC pin voltage. The power switch will not be reset by the oscillator clock in each cycle. If the comparator does not turn off the switch in a cycle, the power switch will be on for more than a full switching period until the comparator is tripped. In this manner, the programmed voltage across the sense resistor is regulated by the control loop.

Frequency Compensation

The RT8474A has an external compensation pin, allowing the loop response to be optimized for specific applications. An external resistor in series with a capacitor is connected from the VC pin to GND to provide a pole and a zero for proper loop compensation. The typical value for the RT8474A is 10k and 3.3nF.

LED Current Setting

The LED current can be calculated by the following equation :

$$I_{LED(MAX)} = \frac{(V_{ISP} - V_{ISN})}{R_{SENSE}}$$

where $(V_{ISP} - V_{ISN})$ is the voltage between the ISP and ISN pins (100mV typ. if CTL dimming is not applied) and the R_{SENSE} is the resistor between the ISP and ISN pins.

Current Limit

The RT8474A can limit the peak switch current with its internal over-current protection feature. In normal operation, the power switch is turned off when the switch current hits the loop-set value. The over-current protection function will turn off the power switch independent of the loop control when the peak switch current reaches around 2A.

Output Over-Voltage Setting

The RT8474A OVP pin provides the Over-Voltage Protection (OVP) function for buck topology only. The OVP sense threshold is referenced to the top side of the LED string with hysteresis. When the voltage difference between the ISP pin and the OVP pin exceeds a threshold of approximately 1.2V, the power switch will be turned off. The power switch can be turned on again once the voltage difference between the ISP pin and OVP pin drops below 1V. The OVP protection voltage level can be set by the resistor divider R3 and R4 across the output capacitor C4 between ISP pin and the bottom end of the LED string, with the center node of the resistor divider tied to the OVP pin. Typically, set $R4 = 10k\Omega$ is suggested.

Over-Temperature Protection

The RT8474A has Over-Temperature Protection (OTP) function to prevent the excessive power dissipation from overheating. The OTP function will shut down switching operation when the die junction temperature exceeds 150°C. The chip will automatically start to switch again when the die junction temperature cools off.

Inductor Selection

Choose an inductor that can handle the necessary peak current without saturating and ensure that the inductor has a low DCR (copper-wire resistance) to minimize I^2R power losses. A 4.7μH to 22μH inductor will meet the demand of most of the RT8474A applications. Inductor manufacturers specify the maximum current rating as the current where the inductance falls to certain percentage of its nominal value, typically 65%. In Multiple-Topology application where the transition between discontinuous and continuous modes occurs, the value of the required output inductor, L, can be approximated by the following equation :

For Buck application :

$$L = \left[\frac{V_{OUT}}{f \times \Delta I_L} \right] \times \left[1 - \frac{V_{OUT}}{V_{IN(MAX)}} \right]$$

The ripple current ΔI_L and peak current I_{PEAK} can be calculated :

$$\Delta I_L = \left[\frac{V_{OUT}}{f \times L} \right] \times \left[1 - \frac{V_{OUT}}{V_{IN}} \right]$$

$$I_{PEAK} = I_{OUT} + \frac{\Delta I_L}{2}$$

For Boost application :

$$L = \left[\frac{V_{IN}}{f \times \Delta I_L} \right] \times \left[1 - \frac{V_{IN}}{V_{OUT}} \right]$$

The ripple current ΔI_L and peak current I_{PEAK} can be calculated :

$$\Delta I_L = \left[\frac{V_{IN}}{f \times L} \right] \times \left[1 - \frac{V_{IN}}{V_{OUT}} \right]$$

$$I_{PEAK} = \left[\frac{I_{OUT} \times V_{OUT}}{\eta \times V_{IN}} \right] + \frac{\Delta I_L}{2}$$

For Buck-Boost application :

$$L = \left[\frac{V_{OUT}}{\Delta I_L \times f} \right] \times \left[1 - \frac{V_{OUT}}{V_{IN} + V_{OUT}} \right]$$

The ripple current ΔI_L and peak current I_{PEAK} can be calculated :

$$\Delta I_L = \left[\frac{V_{OUT}}{L \times f} \right] \times \left[1 - \frac{V_{OUT}}{V_{IN} + V_{OUT}} \right]$$

$$I_{PEAK} = \left[\frac{(V_{IN} + V_{OUT}) \times I_{OUT}}{\eta \times V_{IN}} \right] + \frac{\Delta I_L}{2}$$

where,

V_{OUT} = output voltage.

V_{IN} = input voltage.

I_{OUT} = LED current.

f = switching frequency.

η = efficiency.

Schottky Diode Selection

The Schottky diode, with their low forward voltage drop and fast switching speed, is necessary for RT8474A applications. In addition, power dissipation, reverse voltage rating and pulsating peak current are important parameters of the Schottky diode that must be considered. The diode's average current rating must exceed the average output current. The diode conducts current only when the power switch is turned off (typically less than 50% duty cycle).

Capacitor Selection

The input capacitor reduces current spikes from the input supply and minimizes noise injection to the converter. For most RT8474A applications, a 4.7 μ F ceramic capacitor is sufficient. A value higher or lower may be used depending on the noise level from the input supply and the input current to the converter. In Buck application, the output capacitor is typically ceramic and selection is mainly based on the output voltage ripple requirements. The output ripple, ΔV_{OUT} , is determined by the following equation :

$$\Delta V_{OUT} \leq \Delta I_L \times \left[ESR + \frac{1}{8 \times f \times C_{OUT}} \right]$$

Thermal Considerations

For continuous operation, do not exceed the maximum operation junction temperature 125°C. The maximum power dissipation depends on the thermal resistance of IC package, PCB layout, the rate of surroundings airflow and temperature difference between junction to ambient. The maximum power dissipation can be calculated by following formula :

$$P_{D(MAX)} = (T_{J(MAX)} - T_A) / \theta_{JA}$$

where $T_{J(MAX)}$ is the maximum operation junction temperature, T_A is the ambient temperature and the θ_{JA} is the junction to ambient thermal resistance.

For recommended operating conditions specifications, the maximum junction temperature is 125°C. The junction to ambient thermal resistance, θ_{JA} , is layout dependent. For SOP-8 (Exposed Pad) package, the thermal resistance θ_{JA} is 29°C/W on the standard JEDEC 51-7 four-layer thermal test board. The maximum power dissipation at $T_A = 25^\circ\text{C}$ can be calculated by following formula :

$$P_{D(MAX)} = (125^\circ\text{C} - 25^\circ\text{C}) / (29^\circ\text{C/W}) = 3.44\text{W for SOP-8 (Exposed Pad) package}$$

The maximum power dissipation depends on operating ambient temperature for fixed $T_{J(MAX)}$ and thermal resistance θ_{JA} . The deration curve in Figure 1 allows the designer to see the effect of rising ambient temperature on the maximum power allowed.

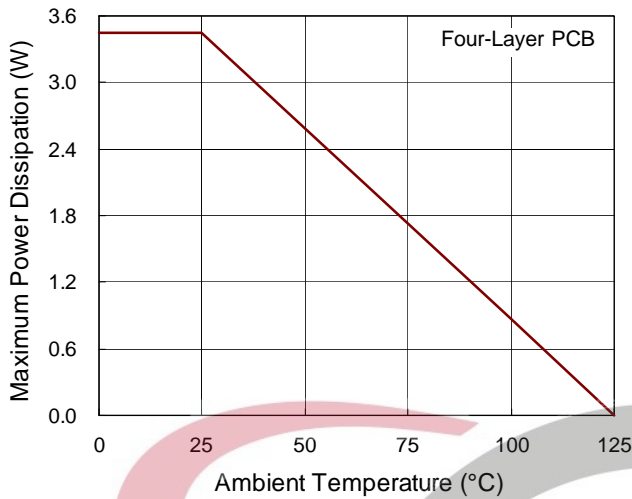

Figure 1. Derating Curve of Maximum Power Dissipation

Layout Considerations

PCB layout is very important when designing power switching converter circuits. Some recommended layout guide lines are as follows :

- ▶ The power components L1, D1 and C4 must be placed as close to each other as possible to reduce the ac current loop area. The PCB trace between power components must be as short and wide as possible due to large current flow through these traces during operation.
- ▶ Place L1 and D1 as close to each other as possible. The trace should be as short and wide as possible.
- ▶ The input capacitor C5 must be placed as close to the VCC pin as possible.
- ▶ Place the compensation components to the VC pin as close as possible to avoid noise pickup.

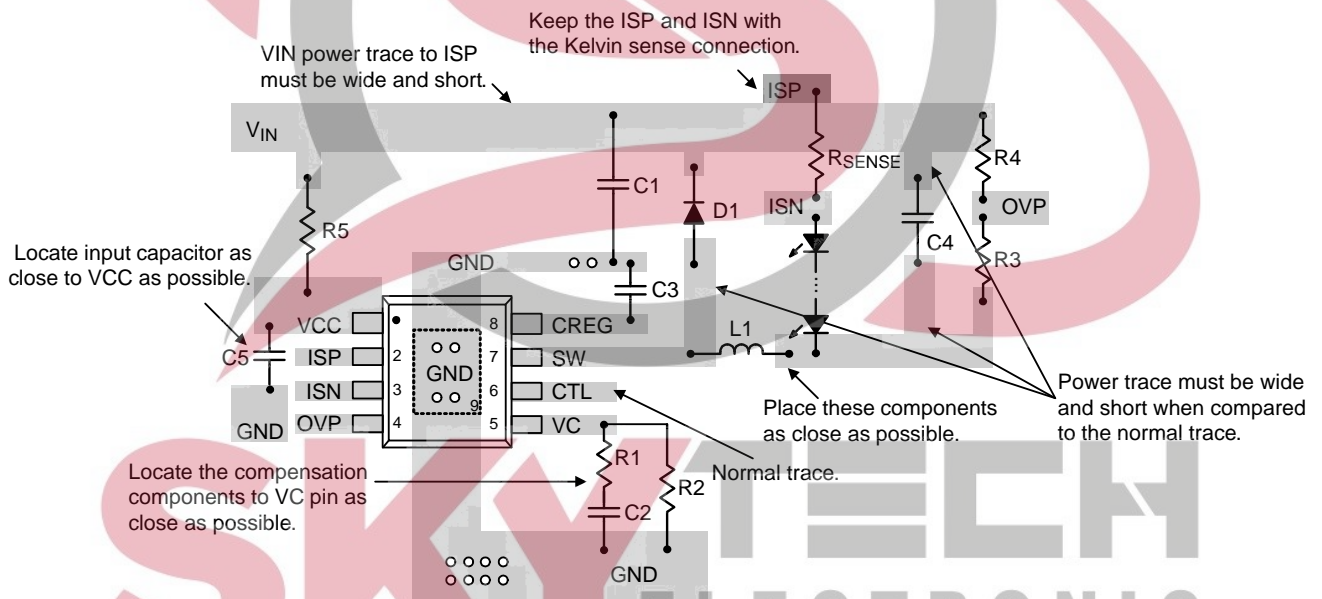
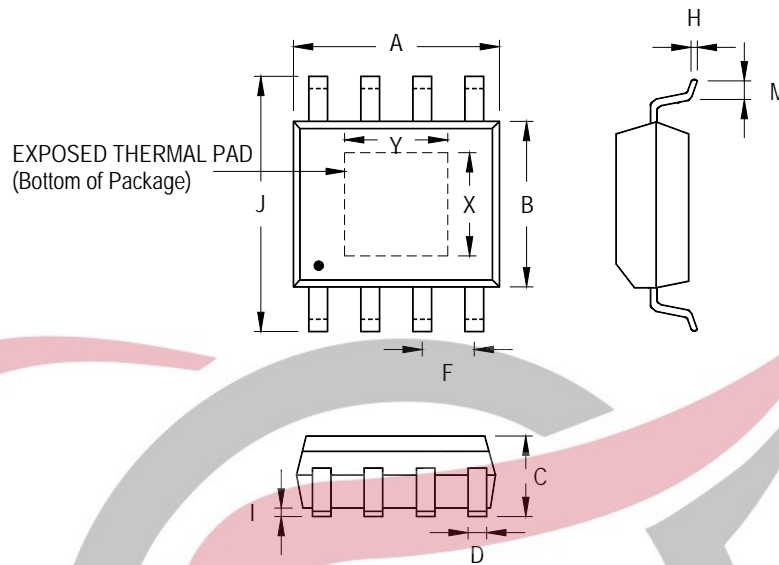

Figure 2. PCB Layout Guide

Outline Dimension



Symbol	Dimensions In Millimeters		Dimensions In Inches		
	Min	Max	Min	Max	
A	4.801	5.004	0.189	0.197	
B	3.810	4.000	0.150	0.157	
C	1.346	1.753	0.053	0.069	
D	0.330	0.510	0.013	0.020	
F	1.194	1.346	0.047	0.053	
H	0.170	0.254	0.007	0.010	
I	0.000	0.152	0.000	0.006	
J	5.791	6.200	0.228	0.244	
M	0.406	1.270	0.016	0.050	
Option 1	X	2.000	2.300	0.079	0.091
	Y	2.000	2.300	0.079	0.091
Option 2	X	2.100	2.500	0.083	0.098
	Y	3.000	3.500	0.118	0.138

8-Lead SOP (Exposed Pad) Plastic Package

Richtek Technology Corporation

14F, No. 8, Tai Yuen 1st Street, Chupei City
 Hsinchu, Taiwan, R.O.C.
 Tel: (8863)5526789

Richtek products are sold by description only. Richtek reserves the right to change the circuitry and/or specifications without notice at any time. Customers should obtain the latest relevant information and data sheets before placing orders and should verify that such information is current and complete. Richtek cannot assume responsibility for use of any circuitry other than circuitry entirely embodied in a Richtek product. Information furnished by Richtek is believed to be accurate and reliable. However, no responsibility is assumed by Richtek or its subsidiaries for its use; nor for any infringements of patents or other rights of third parties which may result from its use. No license is granted by implication or otherwise under any patent or patent rights of Richtek or its subsidiaries.